

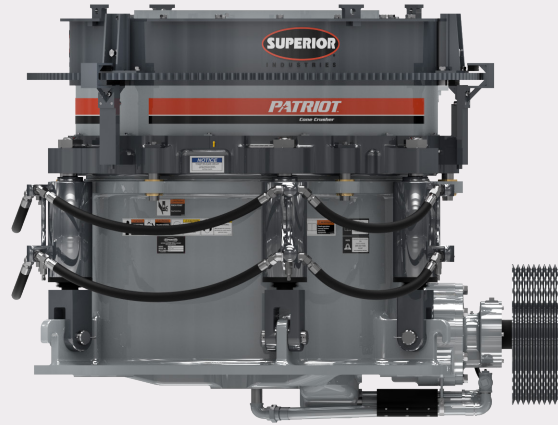

PATRIOT® CONE CRUSHER

MODEL: P400



Head Diameter (mm)	52" (1,320)	Head Angle	50°
Weight (kg)	53,200 lbs. (24,130)	Operating Speed	700-1,000 rpm
Recommended HP (kw)	400 (300)	Stroke/Head Throw (mm)	3.82" (97)
Max. Feed Opening (mm)	12.2" (310)	Counterweight Protection	Guard and headskirt
Setting Adjustment Type	Hydraulic drive	Readout for Accurate CSS	Optional
Thread Lock Type	Hydraulic clamping ring	Tramp Relief	Hydraulic w/ single accumulator
Thrust Bearing Type	Bronze on steel bushing	Chamber Clearing	Hydraulic cylinders
Radial Bearing Type	Bronze bushing		

CAPACITY CHART*

Setting inch (mm)	Min. Capacity sTPH (MTPH)	Max. Capacity sTPH (MTPH)
3/8" (10.0)	140 (127)	200 (181)
1/2" (13.0)	195 (177)	250 (227)
5/8" (16.0)	235 (213)	300 (272)
3/4" (19.0)	265 (240)	340 (308)
7/8" (22.0)	290 (263)	375 (340)
1" (25.0)	310 (281)	415 (377)
1-1/4" (32.0)	340 (309)	465 (422)
1-1/2" (38.0)	375 (340)	525 (476)
1-3/4" (45.0)	430 (390)	580 (526)
2" (51.0)	480 (436)	640 (581)

* All capacities are based on a bulk density of 100 lbs. per cu. ft. and a work index of 13.

LIFTING WEIGHTS

Items	Weight lbs. (kg)
Complete Crusher	53,200 (24,130)
Main Frame Assembly (Main Shaft and Frame Liner)	14,920 (4,840)
Bowl Assembly (Bowl Liner and Hopper Assembly)	10,641 (3,440)
Adjustment Ring (Includes Clamping Ring)	6,770 (2,310)
Head Assembly (Feed Plate Assembly and Mantle)	7,930 (2,110)
Counter-Shaft Box Assembly	1,230 (410)
Eccentric Assembly (Includes Counter-Weight)	3,950 (1,090)
Mantle	2,940 (820)
Bowl Liner	3,390 (840)
Power Unit Dry/Wet	740/1,110 (340/500)
Lube-Air Dry/Wet	1,590/2,410 (690/970)
Lube-Water Dry/Wet	1,490/2,430 (740/1,025)
Air Cooler	1,000 (455)

FEED OPENING DIMENSIONS

FEED OPENINGS			
	A - Min. CSS inch (mm)	B - Max. Feed Opening inch (mm)	C - Max. Feed Size inch (mm)
Standard Coarse	0.875" (22)	12.1" (307)	9.7" (246)
Standard Medium	0.750" (20)	9.5" (242)	7.6" (193)
Standard Fine	0.625" (17)	6.9" (176)	5.5" (139)
Short Head Coarse	0.500" (12)	6.6" (167)	4.8" (121)
Short Head Medium	0.375" (9)	5.1" (130)	3.2" (81)
Short Head Fine	0.375" (9)	4.1" (104)	2.0" (50)

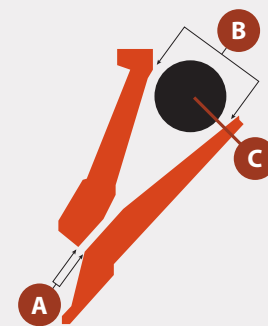

GENERAL DIMENSIONS

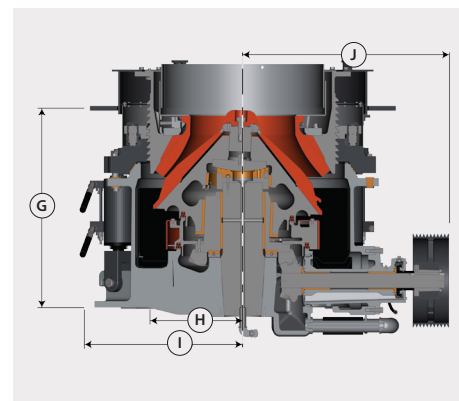
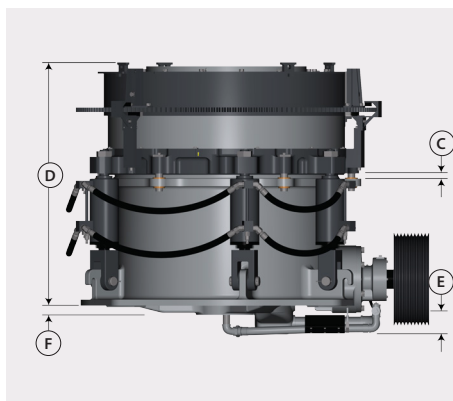
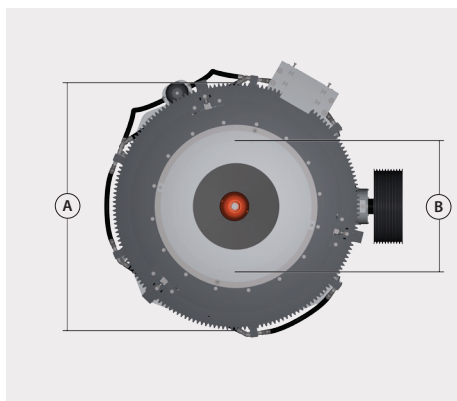

OPERATING DIMENSIONS		
	Description	Dimensions inch (mm)
A	Adjustment Ring Maximum Diameter	115-5/8" (3,012)
B	Inside Diameter Feed Hopper	51-1/2" (1,308)
C	Clearing Stroke Travel	3-1/2" (102)
D	Height of Base to Top of Feed Hopper	79-1/8" (2,010)
E	Base to Bottom of Oil Piping	8-1/2" (217)
F	Base to Bottom of Mainframe Hub	2-5/16" (59)
G	Base to Top of Feed Plate (Anti-Spin)	63" (1,601)
H	Mainframe Flange Minor Radius	34-1/2" (876)
I	Mainframe Flange Major Radius	47-1/2" (1,207)
J	Crusher Centerline to End of Countershaft Assembly	64-5/8" (1,642)

INSTALLATION DIMENSIONS		
	Description	Dimensions inch (mm)
	Counter Shaft Removal Clearance	96-1/4" (2,443)
	Bowl Removal Clearance from Bottom of Hub	101-5/16" (2,573)
	Head Assembly Removal Clearance from Bottom of Hub	102-5/16" (2,599)