

Stackable Conveyors

SUPERIOR



Transfer Multiple Conveyors in One Load

- ▶ Reduces freight expense
- ▶ Quickly transport
- ▶ Easy to setup and start production

Quality Workmanship

- ▶ High resale value
- ▶ Components located inside compact conveyor frame
- ▶ Welds certified by American Society of Mechanical Engineers (ASME)
- ▶ Robust, durable design

Superior Brand Conveying Components

- ▶ CEMA-rated idlers
- ▶ Pulleys
- ▶ Accessories

Multiple Capabilities

- ▶ 24", 30", 36" and 42" belt widths
- ▶ Transfer conveyor
- ▶ Stacking conveyor
- ▶ Low profile bend option



Stackable Conveyor Dimensions

Stackable with Kick Stand Support

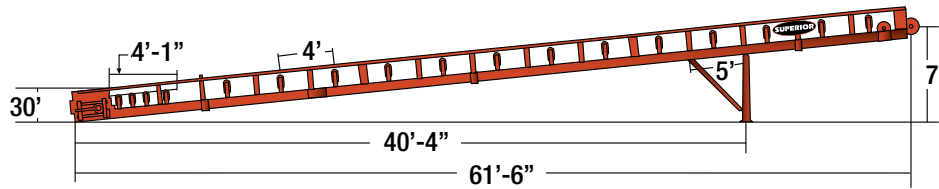

Stackable Plus with Axle Undercarriage Support

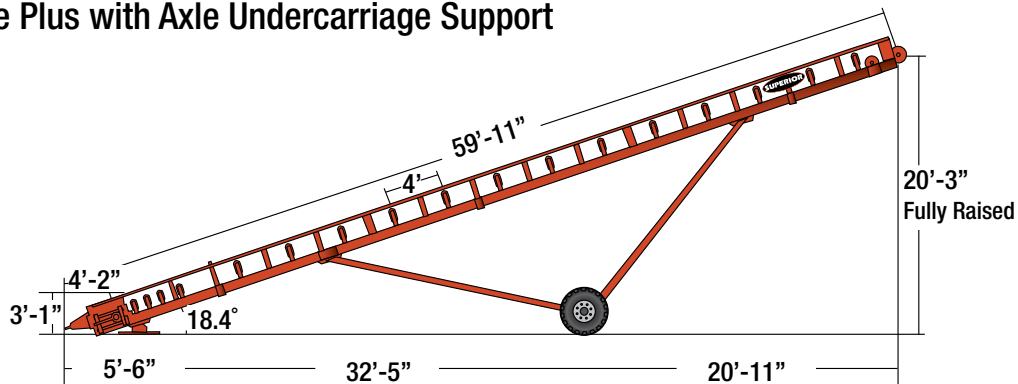

Bend Option

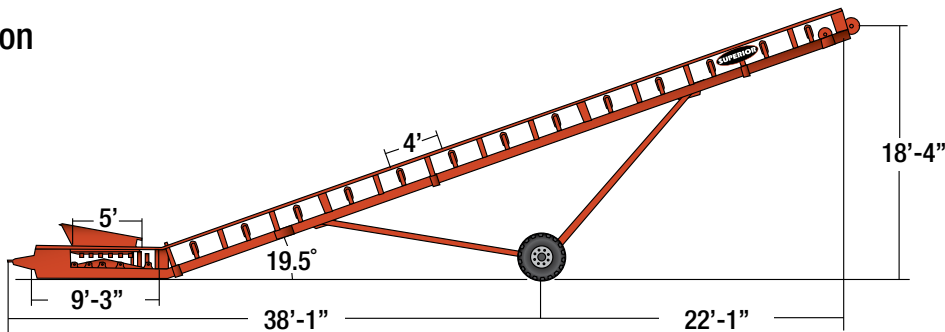

Options

Available Options	Stackable	Stackable Plus
30' to 60' Lengths	X	X
24" to 36" BW	X	X
24" Truss Depth	X	
27" Truss Depth		X
Drive Upgrade		X
Bend Option		X
Kickstand Support	X	X
U-C Options		X
Pit and Road Portable		X
Electrical Package	X	X
Radial Receiving Hopper	X	X
Belt and Idler Upgrade	X	X

For more information or to locate a dealer near you:
www.superior-ind.com or call 1-800-321-1558



© 2009 Superior Industries, LLC. B-104