

# SFL Mine Duty Belt Scraper



Read and understand equipment operators manual before operating or performing maintenance. Failure to do so could result in serious injury or death.

## Installing Belt Scraper

Figure 2

<b>⚠ WARNING</b>
Heed to the following warnings. Failure to do so could result in death or serious injury.
<ul style="list-style-type: none"> <li>• Lockout/Tagout/Blockout before performing maintenance or installation.</li> <li>• Attempting to further tension unit may result in damage.</li> </ul>

## Overview

Figure 1

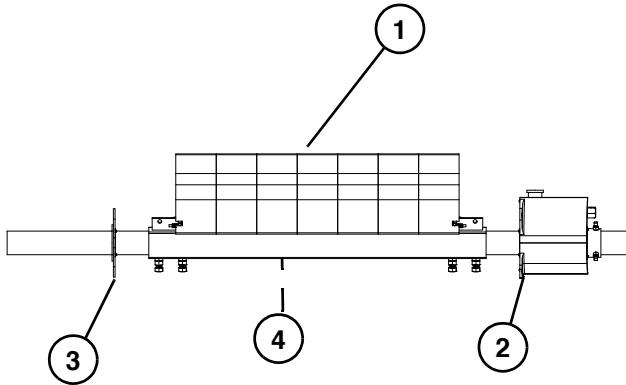

Refer to figure above and description below for SFL Mine Duty Scraper (Figure 1) components:

1. Primary Blade
2. Shaft Tension Assembly
3. Shaft Mounting Bracket
4. Blade Mounting Tube

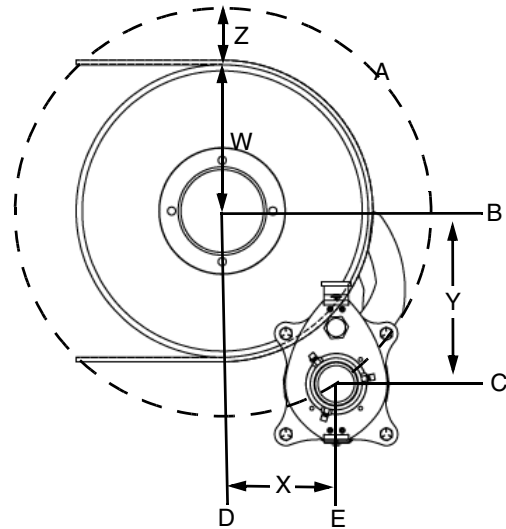

Refer to (Figure 2)

1. Measure distance from center of pulley shaft to outside belt surface "W".
2. Add "Z" value from chart (Figure 2) to "W" measurement draw an arc (Label Line "A").

Note: If no structure is available for hole locating, add additional mounting plate.

3. Draw a horizontal line from center of pulley shaft outward parallel to belt travel (Label Line "B").
4. Measure down from Line "B" value "Y" from chart (Figure 2) and draw a horizontal line parallel to Line "B" (Label Line "C").
5. Draw a vertical line from center of pulley shaft downward perpendicular to belt travel (Label Line "D").
6. Measure across from Line "D" value "X" from chart (Figure 2) and draw a vertical line parallel to Line "D" (Label Line "E").
7. Where Line "A", Line "C" and Line "E" intersect is the center point for shaft mounting bracket.

### NOTICE

- Measurements should always be parallel and perpendicular to belt travel. Proper placement insures proper tension.

**Pulley Diameter 24in (599mm)-30in (762mm)**

Pulley Radius ("W")* in (mm)	("Y") in (mm)	("X") in (mm)	("Z") in (mm)
12 (305)	15 (381)	8 (203.2)	4.625 (117.475)
13 (330)	16 (406.4)	8.25 (209.55)	4.625 (117.475)
14 (356)	17 (431.8)	8.5 (215.9)	4.625 (117.475)
15 (381)	17 (431.8)	10.5 (266.7)	4.625 (117.475)
*includes lagging and belt			

**Figure 3**

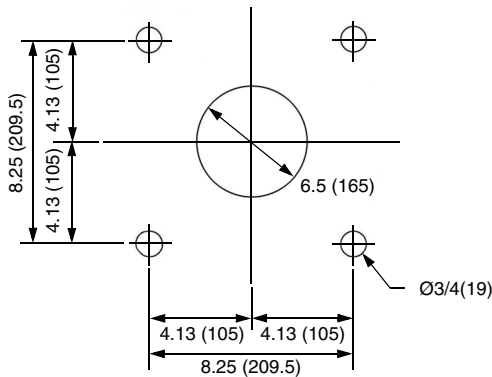

- Drill holes for shaft mounting bracket. Template is also provided with SFL Mine Duty Scraper. (Figure 3)
- Repeat steps 1-9 on opposite side of conveyor.

**Figure 4**

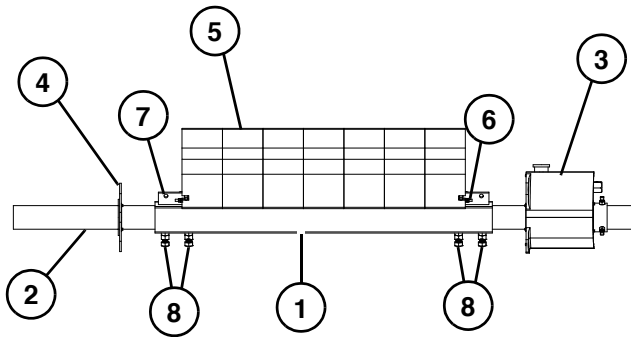

- Place blade mounting tube (1) (Figure 4) into desired position and slide ends of telescoping tube with angles (2) (Figure 4) into mounting tube.

Note: Ensure angle on telescoping tube is fully inserted into mounting tube.

- Slide tensioner assembly (3) and opposite mounting bracket (4) onto telescoping tube and bolt (Figure 4).

Note: Tensioner needs to be installed in the correct direction to operate. When looking from tail toward head on conveyor a tensioner should be mounted on either the left or right of conveyor. Tensioner may be rotated to any convenient position on telescoping tube.

- If blades (5) were removed during installation, Position groove of blades on blade mounting tube and secure blades together with threaded rod (6) on each side of tube. (Figure 4)

Note: Curve of blade faces belt.

- Secure blades with pins (7) (Figure 4).
- Position blade to rest on center of belt.
- Once in desired location tighten bottom bolts (8) (Figure 4) to secure telescoping tube.

**Figure 5**

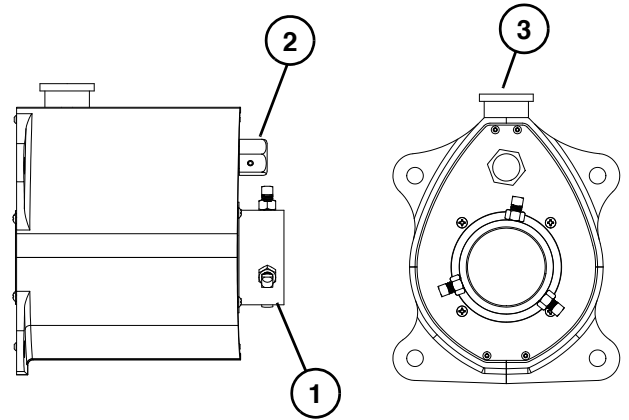

- Turn tensioner sleeve (1) (Figure 5) away from pulley to take up any spring slack and tighten set screws.

Note: While blade stays in contact with belt turn left side tensioner counter-clockwise and right side tensioner clockwise.

- Rotate tensioning nut (2) (Figure 5) to tension scraper.

Note: Ratchet pawl (3) (Figure 5) will move up and down to prevent spring from violently unwinding.

Note: Be sure to rotate nut opposite rotation of scraper tube, away from pulley.

- Rotate tensioning nut until ratchet pawl clicks 7 times. Scraper is now fully tensioned.

Note: Attempting to further tension unit may result in damage.

## Maintenance

### Weekly

- Check primary and secondary blades for excessive wear.

### Blade Replacement

Figure 6

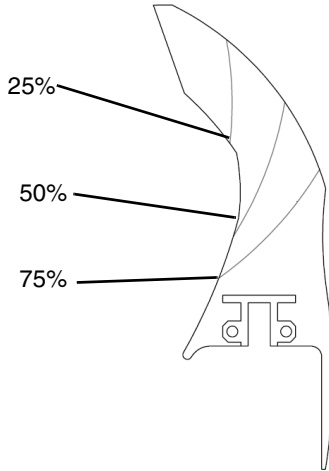

Average for the primary blade (1) (Figure 6) is to replace blade between 50%-75% worn. Material being conveyed determines how often replacement is needed.

Figure 7

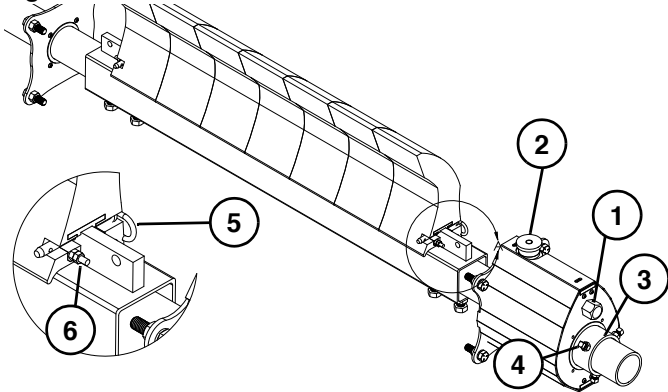

- Use wrench to apply slight pressure in tension direction on tensioning nut (1) (Figure 7).
- Pull and hold ratcheting pawl (2) (Figure 7).

Note: Spring will unwind once ratcheting pawl has been lifted. Use wrench to gently relieve tension.

Note: Be sure to keep control of tensioning nut as it will rotate with spring.

- Once untensioned, loosen set screws (3) on tensioner sleeve (4) so blade can freely rotate (Figure 7).
- Remove pins (5) (Figure 7) from blade edges and pull out blade section.
- Remove threaded rods (6) (Figure 7) from blade inserts and swap out necessary blades.
- Complete steps in reverse to re-install.

## Specifications

Blade Width .....	12in-78in (304.8mm-1981mm)
Primary Blade Material .....	87A Urethane
Fits Belt Widths.....	18in-84in (457mm-2134mm)

## Troubleshooting

If the problem you are experiencing is not listed or the solution does not solve the problem call Superior Industries for help.

Problem	Cause
Excessive blade wear.	1
Blade wears in center more than ends.	2
Insufficient belt cleaning and carry back.	1

- Check mounting location for proper placement.
- Pulley may be crowned. Use 6in or 12in (152mm or 304mm) minus belt width for blade length.

## Replacement Parts

### Blade End (right hand)

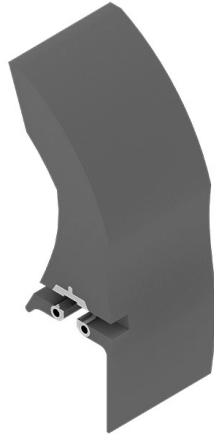

Part Number: 07-01742

### Blade End (left hand)

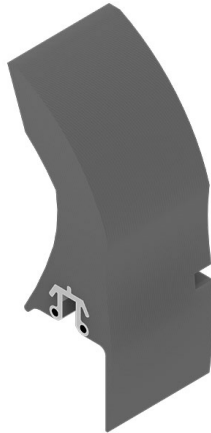

Part Number: 07-01743

### Blade Inner

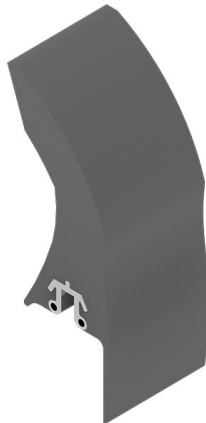

Part Number: 07-01741

## Tensioner Assembly



BLADE WIDTH		PART NUMBERS	
in.	mm	Right Hand	Left Hand
24	600	PMDT-2243Q1	PMDT-2244Q1
30	750	PMDT-4277Q1	PMDT-4278Q1
36	900	PMDT-4279Q1	PMDT-4280Q1
42	1050	PMDT-2245Q1	PMDT-4281Q1
48	1200	PMDT-2243Q2	PMDT-2244Q2
54	1350	PMDT-2243Q2	PMDT-2244Q2
60	1500	PMDT-4277Q2	PMDT-4278Q2
66	1650	PMDT-4277Q2	PMDT-4278Q2
72	1800	PMDT-4279Q2	PMDT-4280Q2
78	1950	PMDT-2245Q2	PMDT-4281Q2
84	2100	PMDT-2245Q2	PMDT-4281Q2
96	2400	PMDT-2243Q2	PMDT-2244Q2
108	2700	PMDT-2243Q2	PMDT-2244Q2