



# CORE SYSTEMS® DESIGN

OEM's Can Achieve 15-30% Savings and Increase Your Margins



## BENEFITS

- » Single source supplier of conveyor drive components
- » Avoid painfully sourcing all pieces and parts on your own
- » Right-sized by engineering team to guarantee functionality
- » One of the largest purchasers of PT components in the world
- » As a result, take advantage of our competitive pricing
- » Pre-assembled packages erase hassle of on-site assembly

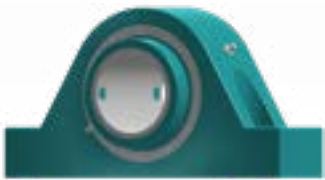
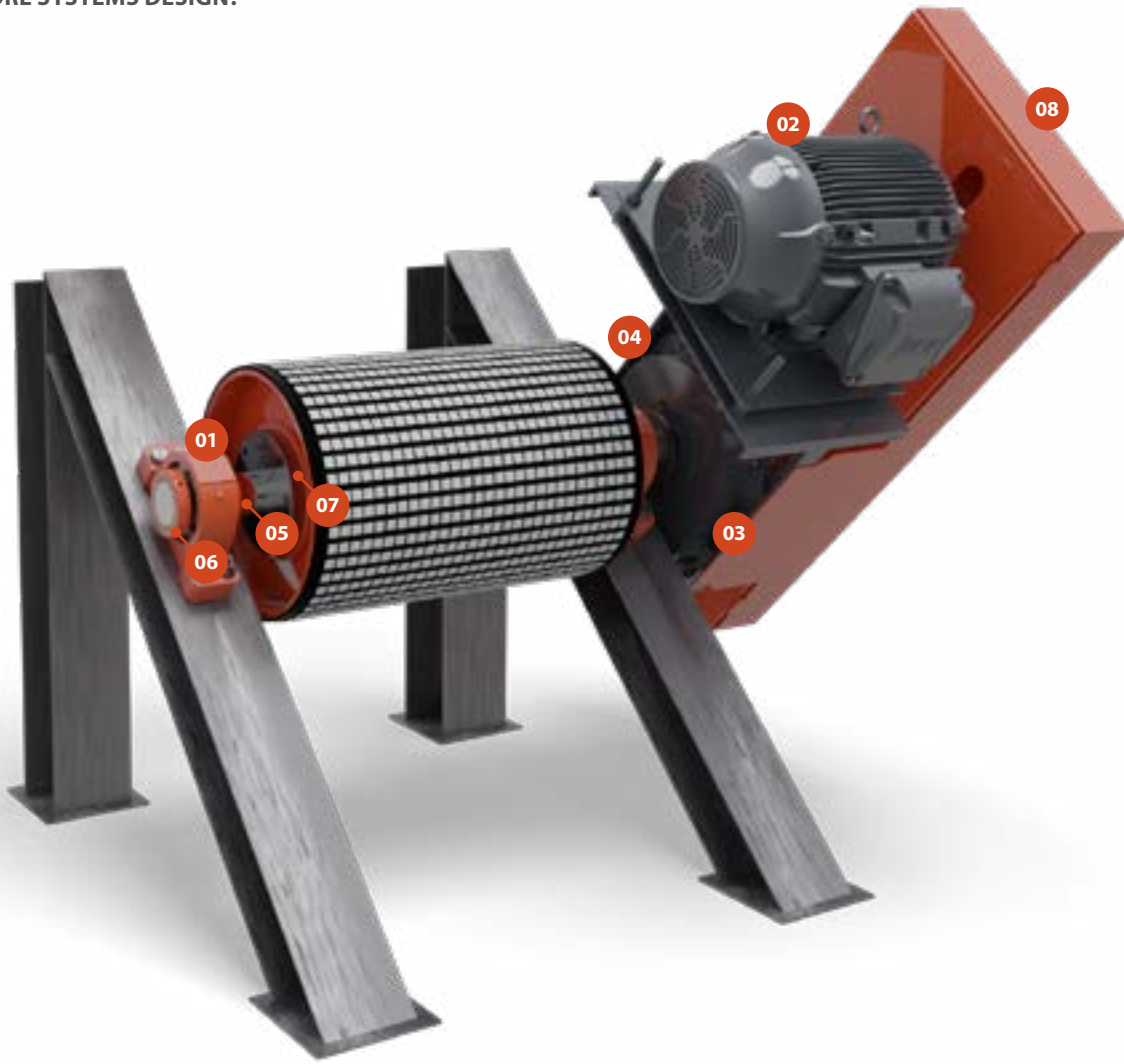

1. BEARINGS



2. MOTORS

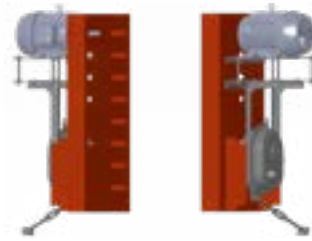

3. DRIVES



4. GEARING



5. SHAFTING



6. COUPLINGS



7. BUSHINGS

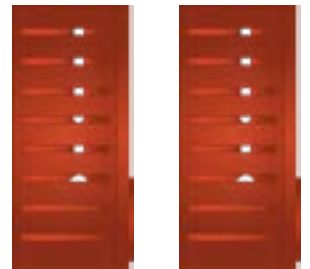

8. GUARDING

## HOW DO WE ACHIEVE YOUR SAVINGS?



### ONE POINT OF CONTACT

- » Design and engineering
- » Quoting
- » Manufacturing
- » Drive package assembly
- » Delivery

### SUPERIOR BUYING POWER

- » Largest buyer of conveyor parts
- » We pass the savings to you

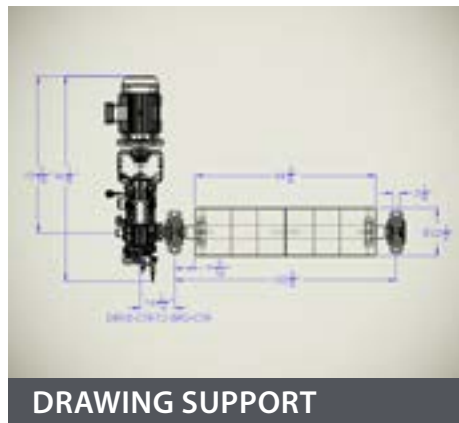

### FREIGHT CONSOLIDATION

- » Consolidation of shipments
- » Stocked warehouses ready for delivery
- » Typical turnaround times are 3-7 days
- » Optional 1-2 day expediting

### PART NUMBER CONVERSION

- » Integration with your back-end
- » Convert to your system
- » Allow us to do the work for you



### DRAWING SUPPORT

- » Drawings available in multiple formats
- » Receive any and all drawing files

### PERFORMANCE-MATCHED

- » Properly designed for application
- » Sized specifically for your conveyor
- » Prevents failures and downtime

### PRE-ASSEMBLED PACKAGES

- » Eliminates assembly time and labor
- » On-site assembly is confusing

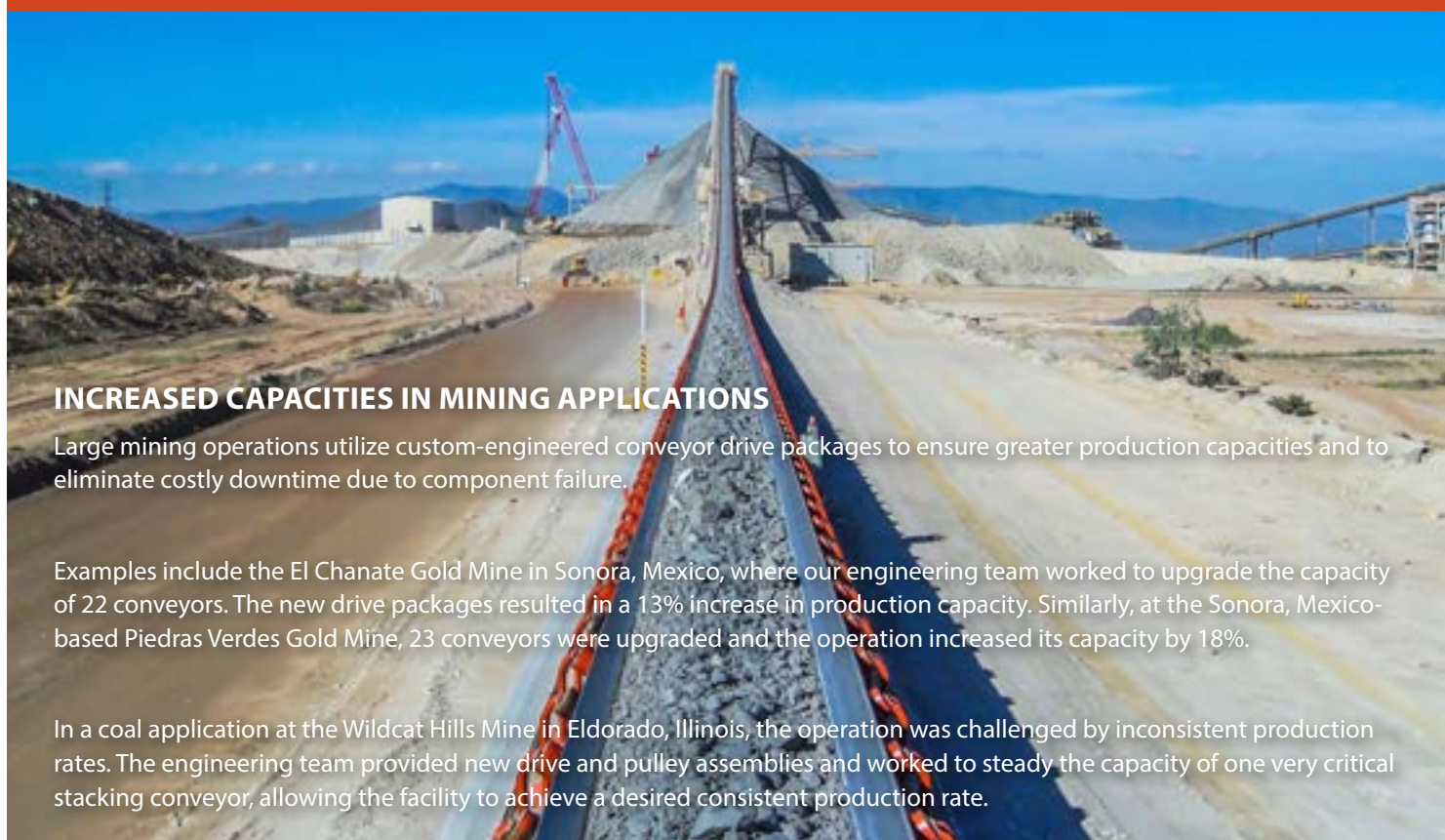

## INCREASED CAPACITIES IN MINING APPLICATIONS

Large mining operations utilize custom-engineered conveyor drive packages to ensure greater production capacities and to eliminate costly downtime due to component failure.

Examples include the El Chanate Gold Mine in Sonora, Mexico, where our engineering team worked to upgrade the capacity of 22 conveyors. The new drive packages resulted in a 13% increase in production capacity. Similarly, at the Sonora, Mexico-based Piedras Verdes Gold Mine, 23 conveyors were upgraded and the operation increased its capacity by 18%.

In a coal application at the Wildcat Hills Mine in Eldorado, Illinois, the operation was challenged by inconsistent production rates. The engineering team provided new drive and pulley assemblies and worked to steady the capacity of one very critical stacking conveyor, allowing the facility to achieve a desired consistent production rate.

## A MAJOR BULK MATERIAL HANDLING OPERATION

Superior recently supplied complete drive packages to Wisconsin-based Agra Industries, a company that designs and fabricates agricultural material handling and storage facilities. Agra Industries was contracted to provide the conveying systems for a new wood pellet facility at the Port of Wilmington on the North Carolina coast.

“Superior Industries has the knowledge and the experience to design the drive packages to fit the parameters that we need,” says Barry Morgan, director of projects for Agra Industries.

Morgan says that the biggest advantage is peace of mind. “I know that I will not question the reliability of these drive packages. If we had provided them ourselves, we would have had to work with at least six different suppliers to even try to match what Superior is doing for us. Plus, it would have required a lot more engineering on our end. Now, I just contact Superior, and their engineers design and deliver the package, allowing our engineers to focus on other high-value projects,” he says.

