

# Extender™ Conveyor



- ▶ Eliminates need for multiple transfer conveyors
- ▶ Reduce freight costs
- ▶ Extends and retracts to meet various transfer lengths
- ▶ Reduce setup time
- ▶ Completely road portable unit

Extender Conveyor	Hydraulic Head Extend	Power Tail Fold	Slide-on Conveyor
Main Frame	80'	80'	80'
Mode and Length of Extension	Telescoping Conveyor with 70' Stinger	Telescoping Conveyor with 50' Stinger and 70' Hydraulic Tail Fold	Telescoping Conveyor with 70' Stinger and 80' Slide-on Conveyor
Total Extension	150'	200'	230'



# Extender Conveyors

## 150' Extender

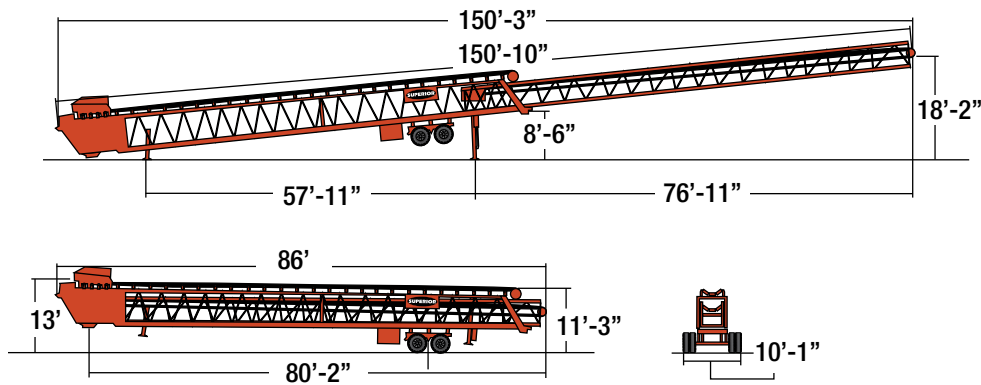

## 200' Extender

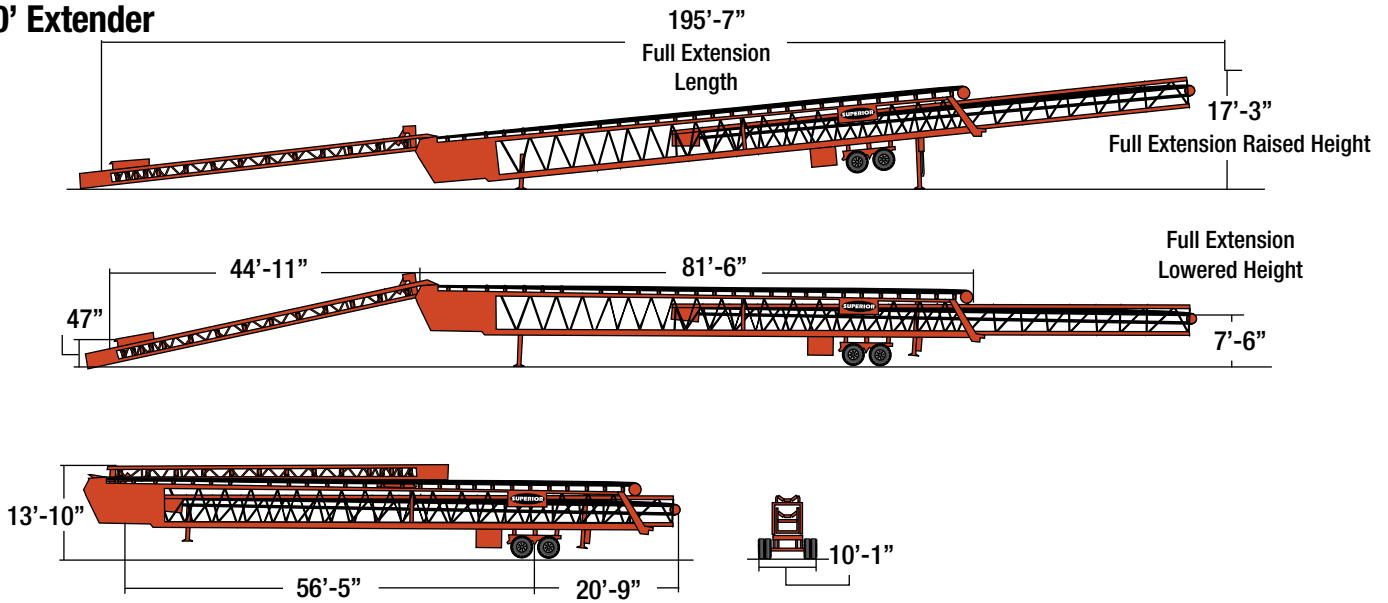

## 230' Extender

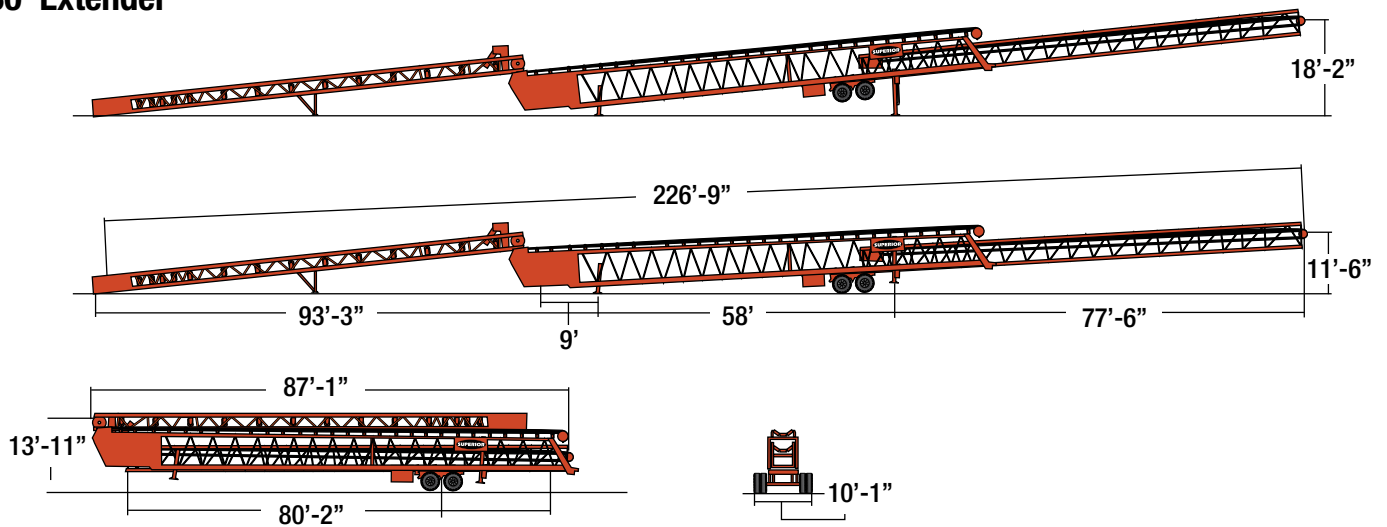

For more information or to locate a dealer near you:  
[www.superior-ind.com](http://www.superior-ind.com) or call 1-800-321-1558



© 2009 Superior Industries, LLC. B-115