

# Tunnel Reclaim Conveyor

**SUPERIOR**



## Decrease Operating Expenses

Keep a continuous feed to your aggregate processing plant all while eliminating the costs associated with extra equipment and staff.

- ▶ Eliminate extra material handling
- ▶ Decrease dependency on loaders
- ▶ Reduce workforce

## Heavy Duty Construction

Our designs are manufactured for equal pressure across the entire length of the tunnel.

- ▶ Operate fully loaded wheel loaders throughout entire length (equivalent to Caterpillar 988G)
- ▶ Operate fully engaged dozers across entire length (equivalent to Caterpillar D10)
- ▶ Continuously welded external seams

## Modular Design

The modularity in our design keeps manufacturing costs stable and allows for flexible, future modifications without replacing entire systems.

- ▶ Dome or box style shape tunnel sections
- ▶ Standard widths of 8', 10' and 12'
- ▶ Vibrating pan or belt feeder box sections available in 24" increments
- ▶ Roof or floor mounted belt feeder options



No tunnel option: Reliance on man and machine.



Tunnel option: Access storage pile at any time.

# Tunnel Reclaim Conveyor

## Box Style Tunnel

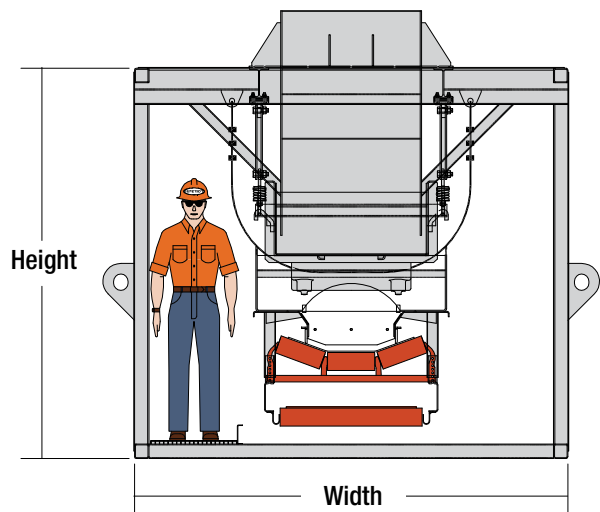

## Dome Style Tunnel

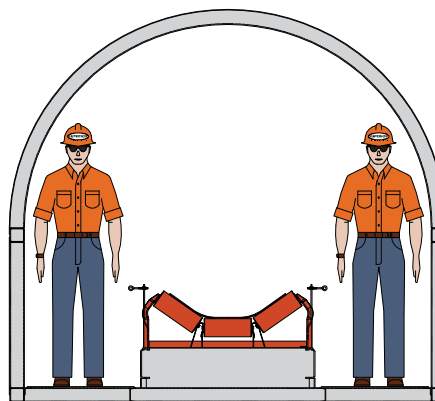

Size	Width	Height	Walkways	Standard Lengths	Additional Increments
8' Tunnel Reclaim	8'	8'	One	17' or 51'	34"
10' Tunnel Reclaim	10'	9'	One or Two	17' or 51'	34"
12' Tunnel Reclaim	12'	9'-6"	One or Two	17' or 51'	34"



For more information or to locate a dealer near you:  
[www.superior-ind.com](http://www.superior-ind.com) or call 1-800-321-1558



© 2009 Superior Industries, LLC. B-126