

Self-Contained

Portable Radial Stacking Conveyor



Onboard Power Supply

A solution for track-mount crushing and screening applications, this stacking conveyor powers itself with an onboard diesel engine.

- ▶ Diesel engine mounted on undercarriage
- ▶ 110 gallon hydraulic tank
- ▶ 70 gallon fuel cell

Specifically Engineered

From fold options to hydraulic packages, customize your conveyor to work for your particular environment and preferences.

- ▶ Top, side, manual or hydraulic folds
- ▶ Hydraulic raise
- ▶ Power travel

Quality Craftsmanship

Superior's comprehensive manufacturing efficiencies are designed to build products and equipment that hold tough to their conditions in the field.

- ▶ Welders certified by the American Society of Mechanical Engineers (ASME)
- ▶ Durable, long-lasting construction
- ▶ Superior brand conveying components

Industry Leading Warranty and Local Support

Backed by the strongest warranty and support program in the industry, Superior's stacking conveyors are built to withstand a harsh working environment.

- ▶ 5 year complete structural warranty
- ▶ 2 year complete conveyor warranty
- ▶ 2 year complete components warranty
- ▶ Local dealer support network



Self-Contained Portable Radial Stacking Conveyor

Transport Specs

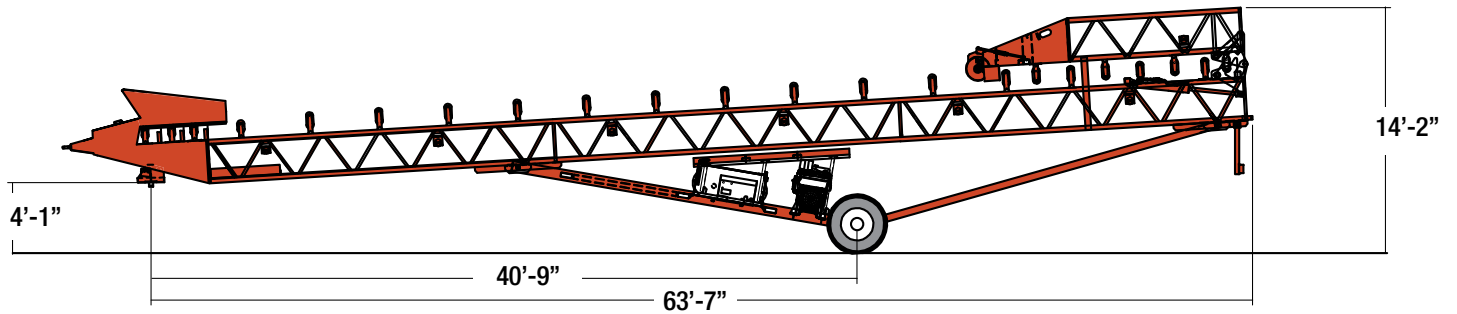

Operating Specs

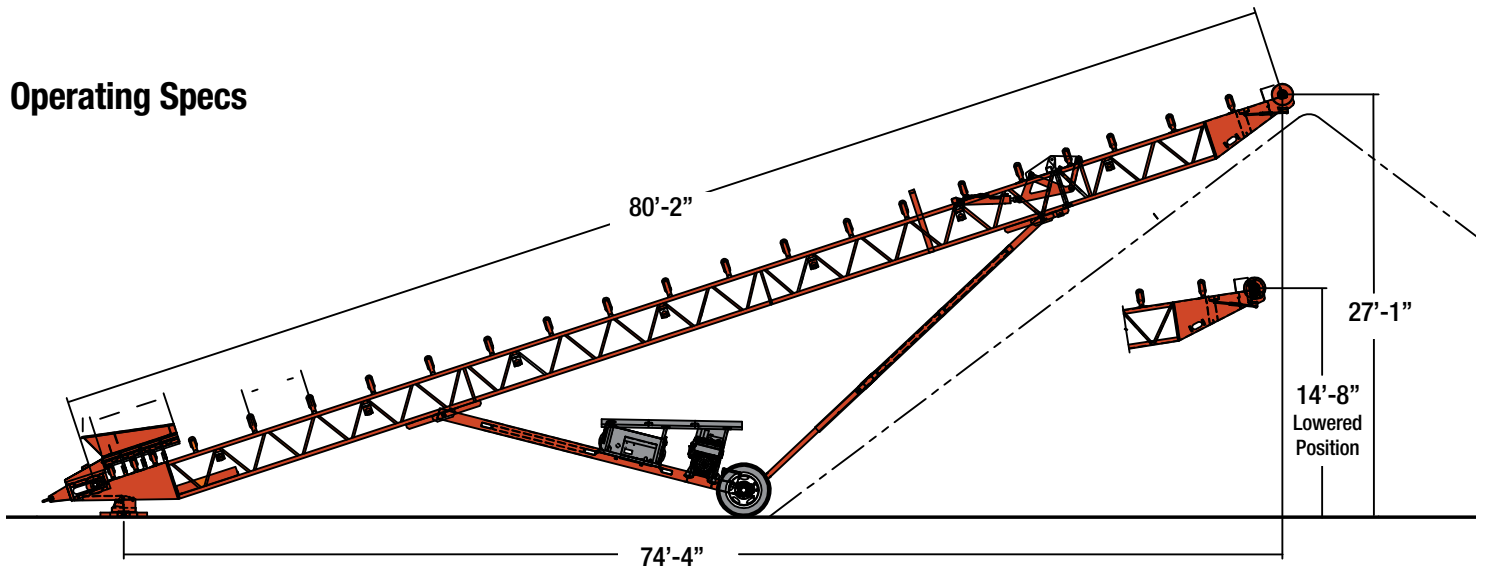

For more information or to locate a dealer near you:
www.superior-ind.com or call 1-800-321-1558



© 2009 Superior Industries, LLC. B-120